



## A new achromatic glass for near infrared laser instruments

Ali H. Al-Hamdani

*Laser and Optoelectronics Engineering Dept. University of Technology, Baghdad, Iraq*

(Received 3 June 2008; accepted 2 June 2009)

**Abstract:** This research investigates new glasses which are best suitable for design of optical systems working in the infrared region between 1.01 to 2.3 $\mu\text{m}$ . This work is extended to Oliva & Gennari (1995,1998) research in which they found that the best known achromatic pairs are (BAF2-IRG2; SRF2-IRG3; BAF2-IRG7; CAF2-IRGN6; BAF2-SF56A and BAF2-SF6). Schott will most probably stop the production of these very little used and commercially uninteresting IRG glasses. In this work equally good performances can be obtained by coupling BAF2, SRF2&CAF2 with standard glasses from Schott or Ohara Company. The best new achromatic pairs found are (SRF2-S-TIH10; CAF2-S-LAL9; CAF2-S-LAL13 and CAF2-S-BAH27). These new achromatic pairs are analyzed by using ZEMAX ray tracing program to design and analyze the same F/2 camera used by Oliva and for the same near infrared region (1.01-2.3 $\mu\text{m}$ ). The results show that these pairs of glass have good performance in infrared design applications.

### Introduction

A lens which is corrected for only one wavelength (color) - e.g. for laser applications - is described as a monochromat, i.e. the monochromatic aberration has been corrected, while chromatic aberrations remain uncorrected. Most lenses for general photography, laser to fiber coupling and wavelength-division multiplexing applications, however, are used in a broader spectrum (wavelength range). Thus the chromatic (color) aberrations of these lenses must also be corrected over a wide spectrum to provide what is generally termed "sharpness". Here, the term "achromat" is used. The most conspicuous color aberration is longitudinal chromatic aberration (LCA). With a monochromat, only the image (or the focus) of one wavelength lies in the image plane due to LCA, while the focus for shorter wavelengths lies in front of the image plane, and behind the image plane for longer wavelengths. Scientists say that "a primary spectrum is present". With an achromat, it is possible to correct the primary spectrum by combining converging and

diverging lens elements made of different types of optical glass displaying different dispersion. To be more precise, it is possible to move the LCA for two wavelengths into the image plane (film plane).

Optical designs of near-infrared (1.0–2.3 $\mu\text{m}$ ) instruments are strongly constrained by a limited selection of near-infrared optical materials. Low-index materials such as CaF<sub>2</sub>, BaF<sub>2</sub>, LiF, NaCl, and infrared-grade fused quartz are commonly used for windows and simple achromatic doublets. However, these low index materials have a restricted range of dispersive power that prevents good chromatic correction in complex, high-performance optical designs. In addition, NaCl, LiF, and BaF<sub>2</sub> are hygroscopic and prone to damage. ZnSe is another material that is suitable for near-infrared lenses, but its high index and large dispersive power limits its usefulness. In addition, the high index of ZnSe makes it difficult to design broadband antireflection coatings [1].

The internal transmission of most optical glasses with intermediate indices and dispersive powers is typically poor at near-infrared

wavelengths, but the internal transmission of the glass S-FTM16 is a fortunate exception [1]. W.R. Brown shows that a 10 mm thick piece of S-FTM16 has an internal transmission of 98.7% at 2.0  $\mu\text{m}$  and 95.3% at 2.4  $\mu\text{m}$ . The dispersive power of S-FTM16 is  $(dn/d\lambda)/(n-1) = -0.036155$  at 1.0  $\mu\text{m}$  and  $-0.026242$  at 2.0  $\mu\text{m}$ . To compare this with other infrared materials, we refer the reader to Table 1 of Epps & Elston (2002), which sorts 24 infrared materials by dispersive power [2]. The intermediate dispersive power of S-FTM16 is quite similar to the Schott glass TIFN5 and somewhat similar to the older Schott glass IRG7. However, TIFN5 and IRG7 are no longer available as stock glasses. So the choice of optical materials is limited by the fact that normal glasses are quit opaque in the infrared due to absorption bands of water which is normally bound in the glass matrix, and sometimes because of absorption intrinsic to the glassy compounds.

For this reason normal glasses were mostly ignored, and the choice of optical materials was traditionally limited to a few crystals such as CAF2, SRF2 and BAF2. Prior to the "re-discovery of Schott IR glasses ( Delabre 1994; Olivea & Gennari 1995) the only glassy material employed in near IR astronomical instrument was IR-grade fused silica. This glass has high dispersion (i.e. is a good flint) but has a very high partial dispersion (cf.Fig.1) and is not suited to produce good achromatic pairs with any of the crowns known. Normal alkaline-earth fluoride crystals have very low dispersion in the near infrared (cf.Fig.1). The main problem faced by those designing IR lenses instrument is therefore to find a high dispersive (flint) material to couple with BAF2, SRF2 or CAF2. The addition for achromatic requires that the flint should have a partial dispersion similar to the alkaline-earth fluoride crystals and this is satisfied by any of the crystalline materials commonly used. However, an excellent match is provided by the Schott IRG glasses which were recently employed in several astronomical instruments working up to 2.3 $\mu\text{m}$  [3]. Unfortunately, the only people who seem interested in IRG2, IRG3 and IRG7 are astronomers, and there is hardly any commercial profit for Schott to continue the production of these glasses [3]. Finding alternatives to the IRG glasses is the main aim of this search which is also intended to give relatively simple solutions for the design of very fast camera for IR spectrographs. In sect. 2 we analyze the

chromatic characteristics of new glasses, define the best flints glass to couple to BAF2, SRF2, CAF2. Representative designs of fast camera for IR spectrographs are discussed in section.3. In section.4 we test the achromatic pairs.

### The selection of Flint glasses

One of the convenient ways to identify the flint glasses which couple with the alkaline-earth fluoride crowns is discussed by Rogers [4,5 ] who stated that the multi-lens system can be achromatized and athermalized with three materials by solving three equations for lens power, achromatism, and athermalization but to find a proper combination of materials, trial and error must be repeated. To avoid time-consuming computation, graphic methods have been developed. Gibbons presented a design method for an athermalized doublet, using a chart where the chromatic and thermal Abbe numbers were plotted[6]. For a triplet, Rayces and Lebach [7] introduced a diagram and showed that chromatic aberration corresponds to the area with a triangle in the diagram. Y. Tamagawa, S. Wakabayashi, T. Tajime, and T. Hashimoto[8] have introduced an athermal chart that plots chromatic dispersive power and thermal dispersive power on a Cartesian coordinate, and they gave the design method of a multi-lens system in contact that satisfies achromatism and athermalization. The advantages of this chart are (1) that the condition of achromatism and athermalization is clear and (2) that the approximate power of the lenses that compose the multi-lens system is easily found on the chart. Design indices are given through a few design examples with an athermal chart.

Another convenient way to identify the flint glasses which couple with the alkaline-earth fluoride crowns is the standard dispersion versus Abbe number plot displayed in figure 1. The most striking result is that SF6 and IRG2 have very similar chromatic characteristics. The refraction indices of IR glasses and alkaline-earth fluoride crystals at standard laser wavelengths are listed in table 1. A convenient method to pre-select a combination of materials which is achromatic over a given  $\lambda_1 < \lambda_2 < \lambda_3$  wavelength range is described by Herzberger & Salzberg [9] and consists of comparing the dispersion P with the modified Abbe number v at suitable wavelength

$$P = \frac{n(I_2) - n(I_3)}{n(I_1) - n(I_3)} \quad (1)$$

$$n = \frac{n(I_2) - 1}{n(I_1) - n(I_3)} \quad (2)$$

In this work, Schott and Ohara glass catalogues were tested to search for the doublets with large  $\Delta v$  and small  $\Delta P$ . Figure 1 is a plot of P versus v for the wavelength range of interest, i.e.  $\lambda_1=1.0140$ ,  $\lambda_2=1.5296$ ,  $\lambda_3=2.6738\mu\text{m}$ , and to find flint glasses matter which lay on the same horizontal line approximately with crown glasses material that present (CAF2, BAF2, SRF2), and best pairs that work on correction the chromatic aberration have the same value P and the larger  $\Delta v$ .

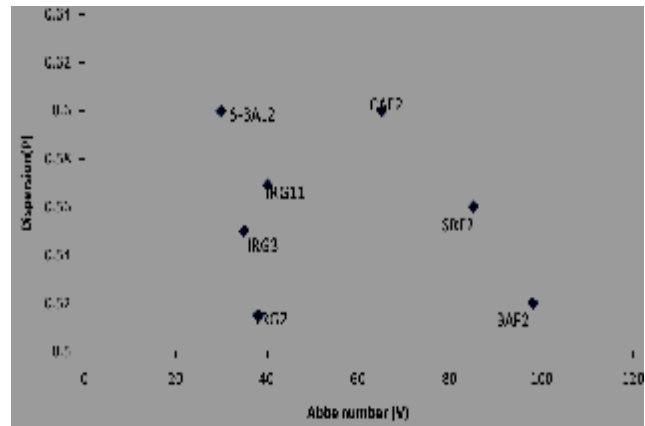

Fig.(1): Plot of NIR Partial dispersion

Table (1): Glass material used in optical design

Glass	$n_{1.013}$	$n_{2.325}$	N	P	Glass	$n_{1.013}$	$n_{1.530}$	$n_{2.325}$	N	P	
BaF2	1.4684	1.4635	95.32310	0.5214	S- BAH27	1.683866	1.67526	1.66253	31.65775	0.596812	
CaF2	1.42879	1.42612	1.42212	63.8860	0.599700	S - T1H14	1.73415	1.78316	1.70916	28.9323	0.55452
SRF2	1.43306	1.43085	1.42803	85.6560	0.56063	S- T1H53	1.81294	1.80013	1.78519	28.8335	0.656936
IRG2	1.8630	1.8526	1.8414	35.4722	0.518518	S- BAH28	1.70396	1.69490	1.68198	31.61504	0.5878071
IRG3	1.8193	1.8089	1.7963	35.16556	0.5550	S- BAL2	1.55886	1.5524	1.54240	33.5625	0.6099635
IRG7	1.5509	1.5442	1.5341	32.3928	0.6011907	S- BAL3	1.55965	1.55341	1.54361	34.79177	0.6109725
IRG11	1.6650	1.6581	1.6491	41.38997	0.566037	S- BAL12	1.52974	1.52370	1.51358	32.40717	0.6126237
IRGN6	1.5777	1.5716	1.5620	36.4076	0.611464	S- BAL14	1.55761	1.55116	1.54050	32.21279	0.6230274
SF2	1.62861	1.62055	1.61003	33.369214	0.5662002	S- BAL42	1.572096	1.56557	1.55463	32.410888	0.6269340
N- Bak1	1.56152	1.55543	1.57455	34.8013	0.61844	S- BAM3	1.569326	1.56243	1.55175	32.01024	0.6072851
N- LAF3	1.70105	1.69297	1.68061	33.9026	0.6046966	S- BAM12	1.62422	1.61653	1.60480	31.74716	0.6040164
N- BAF10	1.65488	1.64714	1.63524	32.9501	0.605906	S- BSM4	1.60107	1.59440	1.58338	33.60094	0.6229508
S- T1H1	1.69353	1.68344	1.67018	29.29937	0.567880	S- BSM9	1.60177	1.59499	1.58406	33.59627	0.6171654
S- T1H3	1.71455	1.70405	1.69065	29.548159	0.5606694	S- BSM22	1.60953	1.60260	1.59157	33.55233	0.6141425
S- T1H4	1.728646	1.71784	1.70430	29.492193	0.5562859	S- BSM25	1.64450	1.63727	1.62613	34.69080	0.6064235
S- BAH27	1.683866	1.67526	1.66253	31.65775	0.596812	S- BSM28	1.60439	1.59740	1.58652	33.430330	0.6088416
S- T1H10	1.70330	1.69286	1.67934	8.91736	0.5642737	S- LAL9	1.67678	1.66822	1.65343	28.61755	0.6334048
S- LAL13	1.67894	1.670446	1.65605	29.28964	0.6286588	S- LAL10	1.70430	1.69567	1.68159	30.5386	0.61999
S- LAL54	1.63815	1.63099	1.61893	32.82466	0.62226	S- LAL12	1.66433	1.65669	1.64414	32.52560	0.62159
S- LAL56	1.66346	1.65585	1.64400	33.702466	0.62226	S- NPH2	1.87807	1.86146	1.84214	23.9760	0.5377122
S- LAM3	1.70111	1.69320	1.68133	35.0455	0.6001112	S- PHM53	1.59256	1.58634	1.57583	35.0472	0.628212
S- LAM51	1.68444	1.67652	1.66451	33.9448	0.602609	S- T1L1	1.52841	1.52176	1.51118	30.37988	0.5821839
S- Lam60	1.72663	1.71730	1.70181	28.90008	0.62409	S- T1L2	1.53537	1.52861	1.51797	30.282066	0.614045
S- LAM66	1.77766	1.76672	1.75094	28.69461	0.590568	S- T1L6	1.51993	1.51343	1.5292	30.183421	0.6172839
S- LAH51	1.76700	1.75740	1.74265	31.104722	0.6057494	S- T1L25	1.65184	1.64258	1.62988	29.26439	0.594538
S- LaH55	1.81413	1.80378	1.78803	30.79616	0.603448	S- T1L26	1.55333	1.54611	1.53493	29.6798	0.607608
S- LAH59	1.79729	1.78784	1.77345	33.04697	0.603448	S- T1L27	1.56047	1.55304	1.54162	29.338992	0.6058554
S- FTM16	1.57569	1.56767	1.55603	28.8743	0.592063	S- T1M2	1.602606	1.59435	1.58240	29.95392	0.5968503
S- T1M25	1.651846	1.642586	1.62958	29.26138	0.5783225	S- T1M22	1.628446	1.61971	1.60753	26.780898	0.58249
S- T1M27	1.62108	1.6124	1.60036	29.56032	0.585424	S- T1M28	1.66699	1.65745	1.64463	29.52177	0.573345
S- T1M39	1.64667	1.6377	1.62567	30.36952	0.575714						

**Practical application**

To demonstrate the quality of achromatic pairs described above we present the preliminary design of F/2 (4 lenses) camera for near infrared spectrometer [9] Figure (2), shows the layout and ray tracing of the optical system, and the details of lenses are listed in table 2.

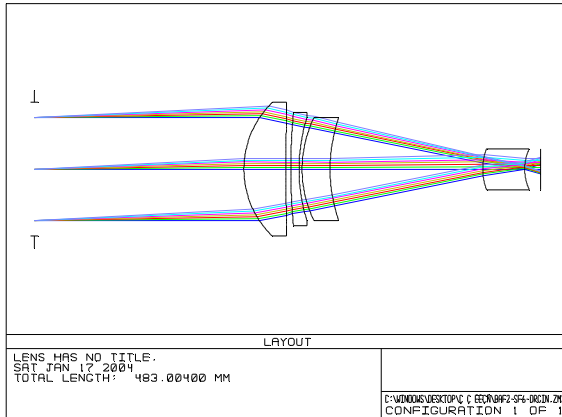

**Fig.(2):** Layout and ray tracing of F/2 near-IR camera

**Table (2) Details of the camera [9]**

(a)  $A = 3.216 \times 10^{-7}$ ,  $B = 5.426 \times 10^{-11}$ ,  $C = -6.352 \times 10^{-15}$ ,  $D = 5.526 \times 10^{-18}$

Surface	Radius (mm)	Thickness (mm)	Material
Source	$\infty$	$\infty$	
Stop		200	
Lens 1	91.6531	40.00	Crown glass
Lens 1	1944.23	4.761	
Lens 2	605.277	7.823	Flint glass
Lens 2	167.455	3.000	
Lens 3	116.127	26.62	Crown glass
Lens 3	152.138 <sup>a</sup>	145.8	
Lens 4	57.9477	40.00	Flint glass
Lens 4	48.2670	15.00	
Array	$\infty$	0	

**Test the selected achromatic pairs by using Zemax program**

**Chromatic focal shift**

Chromatic focal shift is one of the layouts of ZEMAX program through which the optical system is tested from the chromatic aberration.

system is tested from the chromatic aberration. Remember that the chromatic focal change for single lens that suffer from acute chromatic aberration was  $8000\mu\text{m}$ [10].

After testing all pairs in Schott catalogue by using ZEMAX program, the chromatic focal shift for these new materials were shown in table (4).The chromatic focal shift for the old pairs [3,9] are shown in table(3).

These pairs have focal shift range between  $(366.3316-1696.0045)\mu\text{m}$ . Depending on the transmission coefficient reported by Schott and Epps & Elston [2], The best achromatic pairs were selected. Figures (3-A,B,C and D) shows the chromatic focal shift for the chosen new pairs (CAF2-S-BAH27, CAF2-S-LAL13, SRF2-S-TIH10, CAF2-S-LAL9).

This means that the new pairs are good compared with the chromatic shift of a single lens, and it approaches to the chromatic shift values in the pairs that used previously by [3,9] as shown in Figures (4,E,F,G and H ) and table(3) which have shift range between  $(13.443-1905)\mu\text{m}$ . Also it was noticed that some new glass pairs have parabola curves which mean that they can be used for designing more than two wavelengths at the same time.

**Table (3):** Chromatic focal shifts and the radial distances at 80% and 90% of the Encircled energy by ( Delabre 1994;Olivea & Gennari 1995,1998)

Glass	Chromatic focal shift $\mu\text{m}$	Radial distance at 80% Encircled energy $\mu\text{m}$	Radial distance at 90% Encircled energy $\mu\text{m}$
BAF2-N-SF56A	13.443	3600	4400
BAF2-SF6	23.4426	3100	3800
BAF2-IRG3	97.2956	2000	2700
BAF2-IRG2	265.0990	4200	5000
CAF2-IRG7	14440.1959	4400	5200
SRF2-IRG3	1530.0520	2700	2800
CAF2-IRGN6	1667.6196	3600	4400
CAF2-MGO	1823.5136	1430	1500
CAF2-IRG11	1905.4332	1200	1800

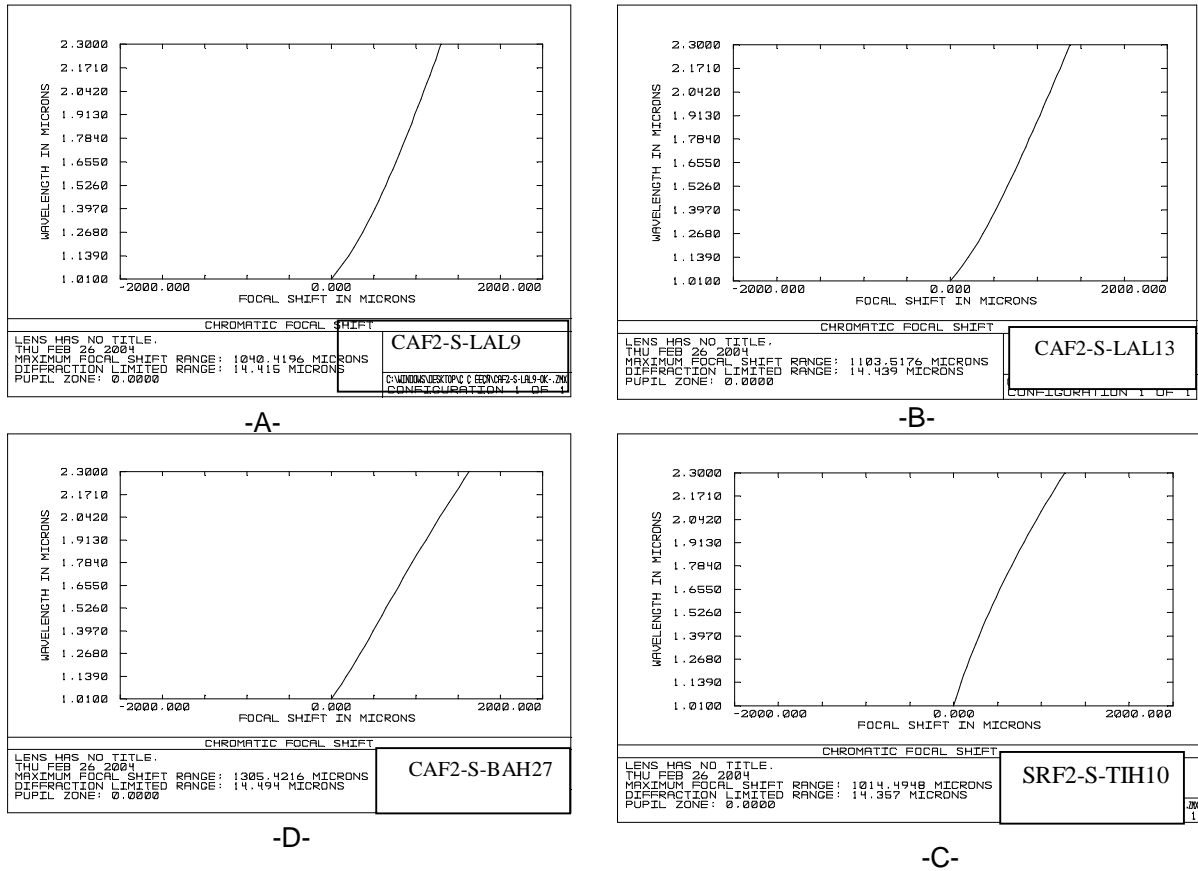

**Fig. (3):** Chromatic focal shift for new pairs

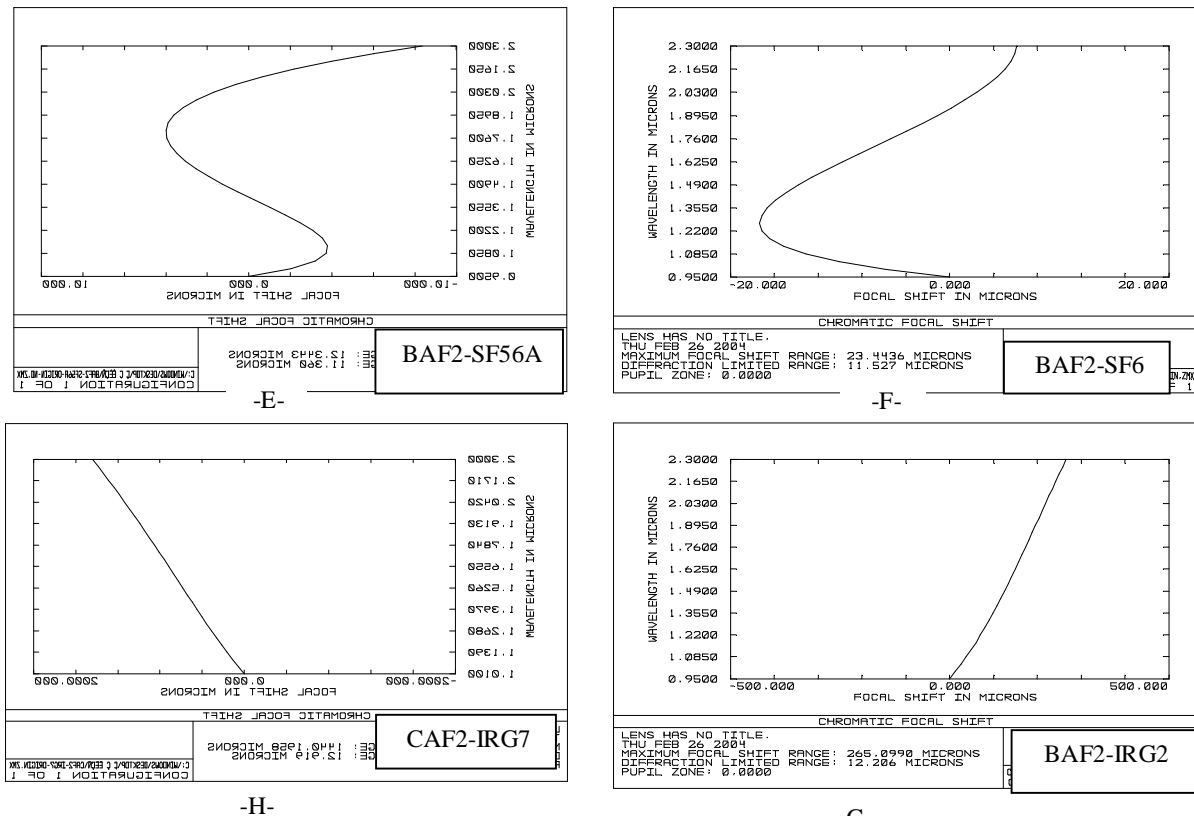
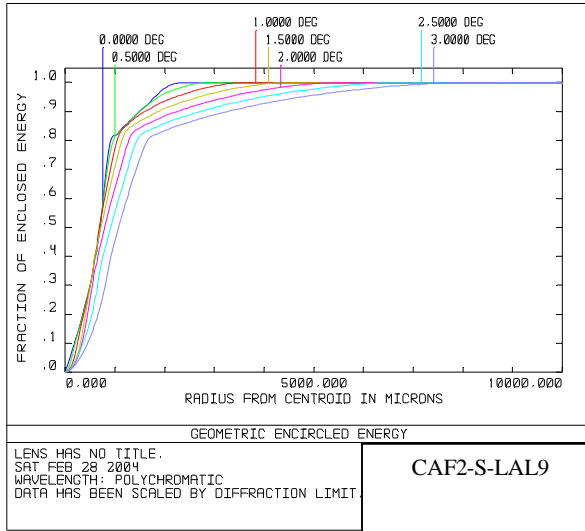

**Fig. (4):** achromatic focal shift pairs by (Delabre 1994; Olivea & Gennari 1995)

**Geometric accumulated energy plot**

The accumulated energy is one important criteria in analyzing optical system. Its curve slope or the radius of the circular containing 80% or 90% of the accumulated energy indicate the performance of the optical system. As the curve slope is small or the circular radius at 80% or 90% of the accumulated energy is small then the optical system has good performance.

Figures (5-A,B,C and D ) show example of the best new chromatic pairs while table(4) show spot radius at 80% and 90% of the accumulated energy to be with in the range (1000-4400)  $\mu\text{m}$  and (1000-6400 )  $\mu\text{m}$  respectively. Table (3) shows that [3,9] pairs have radia distance at 80% and 90% encircled energy in the ranges between (1200-4400)  $\mu\text{m}$  and (1500-5200)  $\mu\text{m}$  respectively Figures (6-E,F,G and H) .



-A-

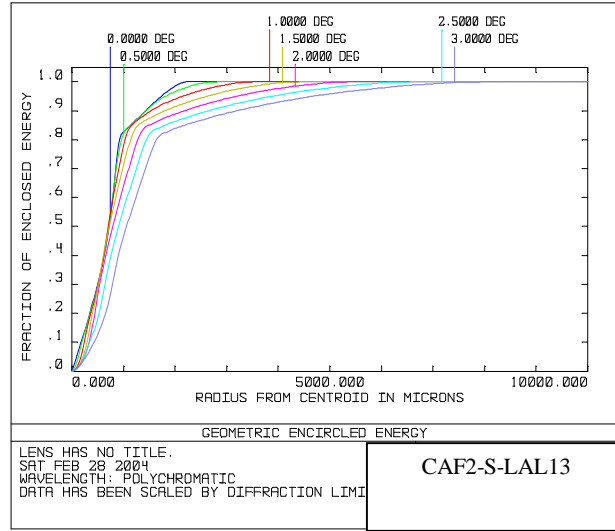

-B-

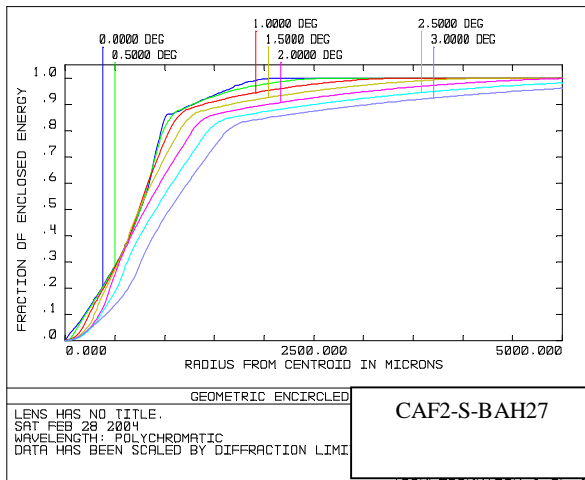

-D-

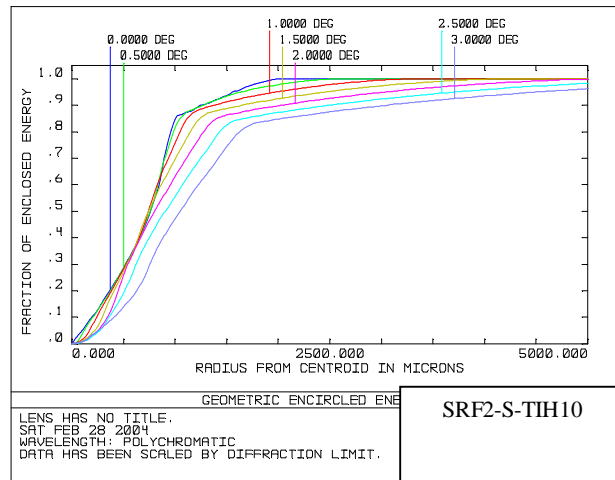

-C-

**Fig. (5):** Accumulated energy for the new pairs

**Table (4):** Chromatic focal shifts and the radial distances at 80% and 90% of the encircled energy for the new pairs of glasses

Glass	Ch. F. shift $\mu\text{m}$	R <sub>80%</sub> ENC	R <sub>90%</sub> ENC	Glass	Ch. F, shift $\mu\text{m}$	R <sub>80%</sub> ENC	R <sub>90%</sub> ENC
BAF2-S-TIH14	366.3319	4200	5000	SRF2-S-TIL6	1303.7894	4200	4800
BAF2-N-SF56	400.7027	3700	4400	CAF2-S—BAH27	1305.4216	1600	3100
SRF2-S-NPH2	447.4284	3600	3700	CAF2-S-LAH51	1308.163	1500	2350
CAF2-S-NPH2	492.5623	3950	4000	CAF2-S-TIL6	1328.4686	1050	5100
SRF2-S-TIH53	969.6675	2500	2550	CAF2-S-BAM12	1349.0884	1000	6200
SRF2-S-TIH14	992.9990	4200	5000	CAF2-S-LAL10	1375.0687	2250	6400
SRF2-N-SF56	994.1110	1600	1650	CAF2-S-LAL12	1386.4030	1000	6400
SRF2-S-TIM35	1013.1139	1500	2000	BAF2-S-BAF10	1391.7011	1200	6800
SRF2-S-TIH13	1013.8739	1050	1150	CAF2-S-BAM3	1408.4319	1000	1300
SRF2-S-TIH10	1014.4948	1000	1300	CAF2-N-BAF10	1420.7074	1050	2150
CAF2-S-LAM66	1033.7208	2250	2300	CAF2-S-LAL54	1421.6802	1700	6200
CAF2-S-LAL9	1040.4196	1000	1500	CAF2-S-BAL14	1431.8351	2100	3000
SRF2-S-TIH4	1053.3439	1200	1300	SRF2-SF2	1433.0292	1000	1250
SRF2-S-TIH1	1056.2637	1000	1600	CAF2-S-BAL42	1434.9653	1450	1900
SRF2-S-TIH3	1058.7042	1050	1150	CAF2-S-BAL12	1466.3192	2700	2600
SRF2-S-TIM28	1091.7837	1700	2300	SRF2-S-LASFN9	1472.1159	3700	4600
SRF2-S-TIM25	1092.3619	2100	2700	CAF2-S-LAL56	1472.576	3000	2100
CAF2-S-LAL13	1103.5176	1000	1500	CAF2-N-LAF3	1473.2046	2000	2600
CAF2-S-LAM60	1114.3726	1450	1550	CAF2-S-BSM28	1481.1572	2200	5000
SRF2-S-TIM22	1147.9919	2700	3400	CAF2-S-BSM22	1486.3587	4400	3400
CAF2-S-FTM16	1163.9250	3700	4500	CAF2-S-LAH59	1488.0127	3800	4500
CAF2-STIM2	1181.0995	3000	3700	CAF2-S-BSM9	1493.9282	5000	5800
SRF2-S-TIL25	1184.1936			CAF2-S-BSM4	1494.944	2700	2800
SRF2-S-TIM39	1193.3584	2200	2900	CAF2-S-BAH11	1528.7487	1300	1900
CAF2-S-TIL25	1207.9182	4400	5300	CAF2-S-BAL2	1514.5359	1150	1200
CAF2-S-TIL27	1220.5860	4100	4900	CAF2-S-BSM25	1545.3944	2900	3600
CAF2-S-LAH55	1221.0204	2900	3000	CAF2-S-BAL3	1571.2129	2700	3400
SRF2-S-TIM8	1229.9730	2900	3700	CAF2-S-PHM53	1589.4839	2600	2700
CAF2-S-TIM27	1229.9730	2950	3700	CAF2-S-LAM51	1675.0754	4100	4900
CaCAF2-S-LAH52	1240.5128	6400	7400	CAF2-S-LAM3	1675.0754	3200	3900
CAF2-S-TIL26	1254.9628	4100	5000	CAF2-N-BAK1	1696.0045	1100	1200
SRF2-S-BAH28	1262.0233	1800	2400	SRF2-S-TIL2	1301.0885	1250	1350
SRF2-S-TIL1	1300.8867	4000	4900				

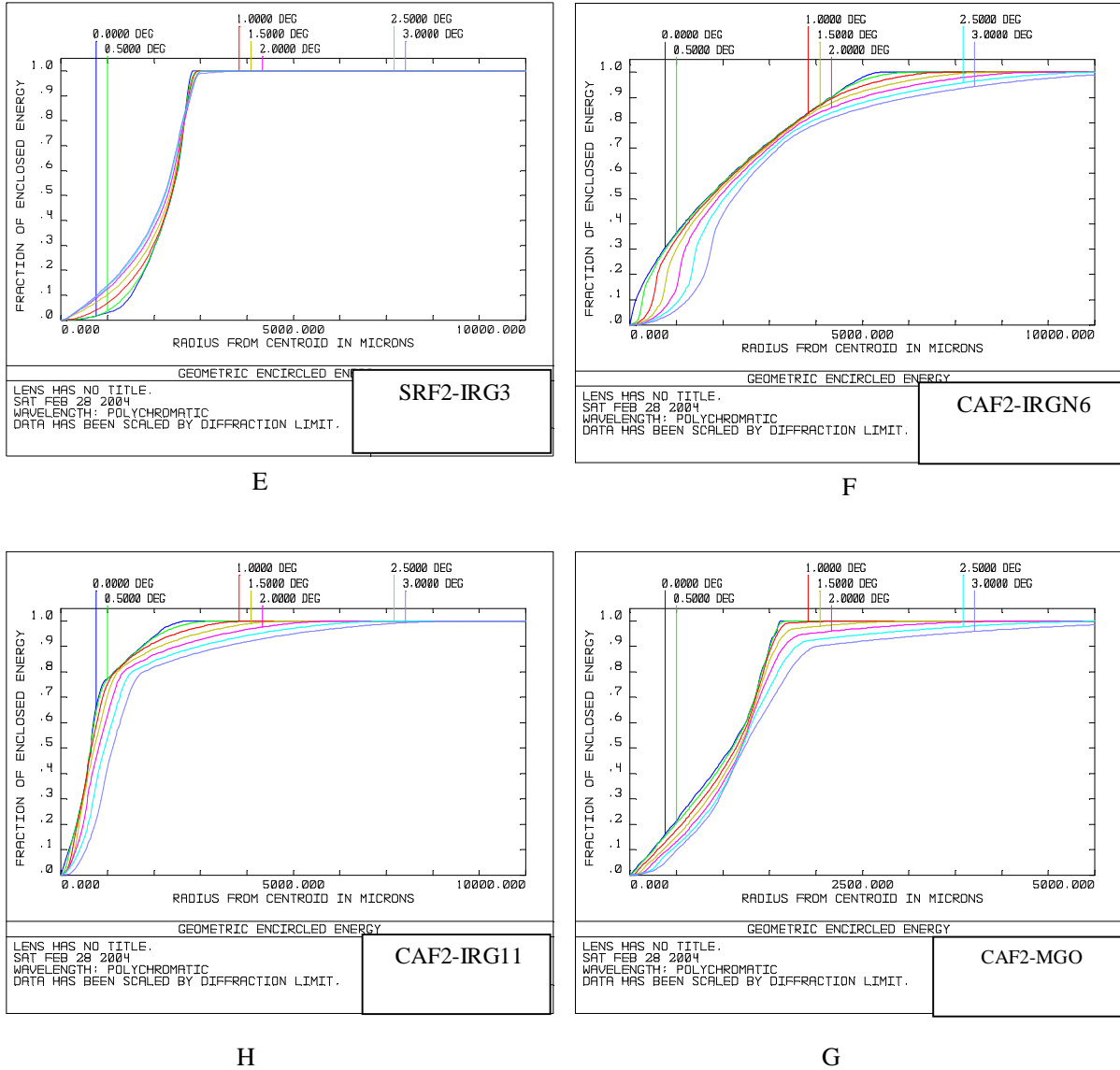

Fig. (6): Accumulated energy by (Delabre 1994; Olivea & Gennari 1995)

### Conclusions

New flint glass is used instead of IR Schott glass because there is hardly any commercial profit for Schott to continue the production of these glasses. Finding good alternatives to IRG glasses is the main aim of this work which is also intended to give relatively simple solutions for the design of the very fast cameras for IR spectrographs. We have shown that lens systems which are achromatic over the full (1-2.3)  $\mu\text{m}$  range can be easily obtained using alkaline-earth

fluoride crystals coupled with (S-TIH10, S-LAL13, S-BAH27, S-LAL9) Ohara and Schott glasses. The best combinations are [SRF2-S-TIH10, CAF2-S-LAL9, SAF2-S-LAL13, CAF2-S-BAH27]

### References

1. H. W. Epps, W. R. Brown and D. G. Fabricant Astronomical Society of the Pacific, **116**, 833–841(2004).



2. H.W. Epps, R.J. Elson, Proc. SPIE, 4841,1280 (2002).
3. E. Oliva, S. Gennari, Astronomy and Astrophysics Supplement series, **114**, 179-182 (1995).
4. P. J. Rogers, Proc. Soc. Photo-Opt. Instrum. Eng. **1354**, 742-751 (1990).
5. R. Hartmann and W. J. Smith, Proc. Soc. Photo-Opt. Instrum. Eng. CR38, 69-93 (1990).
6. R. C. Gibbons, U.S. patent, **4**, 431, 917 (1984).
7. L. Rayces and L. Lebach, Proc. Soc. Photo-Opt. Instrum. Eng. **1354**, 752-759 (1990).
8. Y. Tamagawa, S. Wakabayashi, T. Tajime, and T. Hashimoto, Applied optics, **33**, 34 (1994).
9. E. Oliva, S. Gennari, Astronomy and Astrophysics Supplement series, **128**, 599-603, (1998).

## زجاج لالوني جديد لمنظومات ليزر الأشعة تحت الحمراء

علي هادي الحمداني

قسم هندسة الليزر والبصريات الألكترونية، الجامعة التكنولوجية ، بغداد ، العراق

**الخلاصة**  
زجاج جديد ملائم للمنظومات البصرية العاملة في مدى الأشعة تحت الحمراء بين (1.01 و 2.3 مايكرومتر) قد تم استقصائها في هذا البحث. هذا البحث هو استمرار لبحث Oliva & Gennari (1995 و 1998) والذي وجدوا فيه الأزواج اللالونية المعروفة جيدا -BAF2-IRG2; SRF2-IRG3; BAF2-IRG7; CAF2-IRGN6; BAF2-SF56A and BAF2-SF6). أوقفت شركة Schott إنتاج هذا النوع من الزجاج لقلة استخدام وعدم الرغبة بزجاج IRG تجاريا. في هذا البحث تم إيجاد زجاج مساويا بالأداء عن طريق جمع BAF2, SRF2&CAF2 مع الزجاج من شركتي Schott و Ohara واستخلصت الأزواج اللالونية الجديدة (SRF2-S-TIH10; CAF2-S-LAL9; CAF2-S-LAL13 and CAF2-S-BAH27) تم تقييم هذه الأزواج اللالونية باستخدام برنامج التصميم ZEMAX وذلك بتصميم المنظومة البصرية المستخدمة من قبل Oliva & Gennari و لنفس مدى الأشعة تحت الحمراء (1.01 و 2.3 مايكرومتر). اوضحت النتائج أن الأزواج الجديدة تمتلك أداء جيد في تطبيقات الأشعة تحت الحمراء.